

The San Francisco Billiard Academy

Presents:

Progressive Practice

Drills

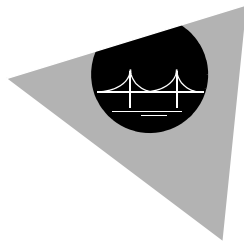

SFBA



B C A

*“What a feeling to shoot better and consistently.
We’ll show you the way.”*

Progressive Practice

Progressive Practice Drills

Goal: Improve cue ball control and basic aiming with structured drills.

Technique: Shoot a shot that needs a specific skill, and if successful, make the next shot harder, but if not successful, make the next shot easier. After ten or so shots, note your skill level.

Examples: Two spin drills:

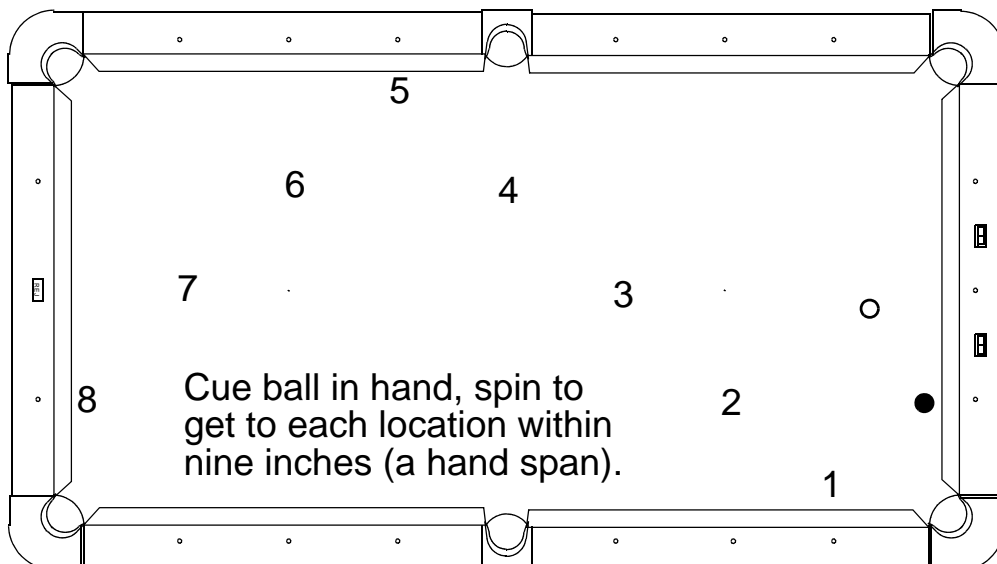
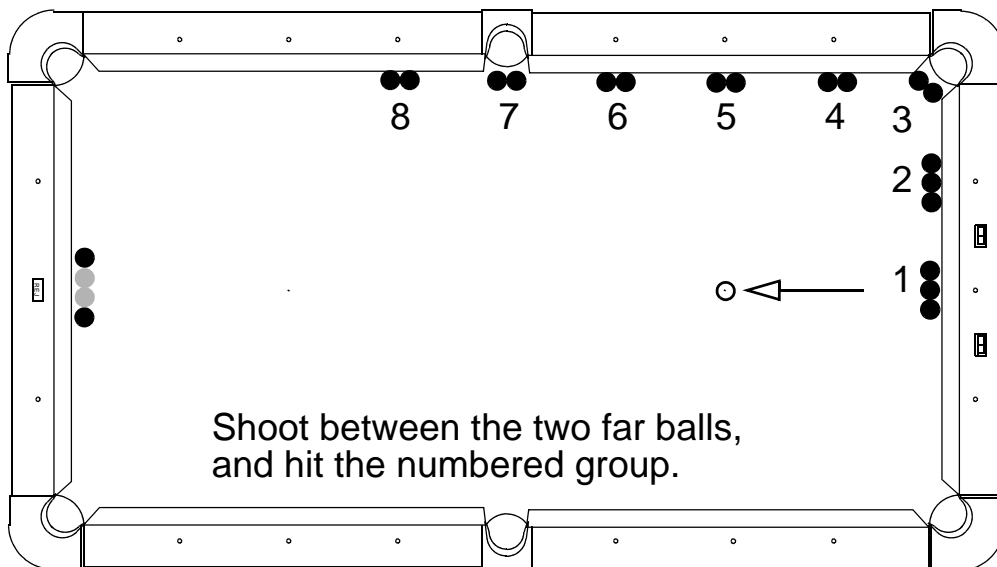

Progressive Practice

Progressive Practice

permits precise pocketing percentage predictions.

By Bob Jewett, originally published in Billiards Digest, Dec. 1992

The “progressive practice” method described below has big advantages over standard drills. It automatically adjusts the difficulty of the shots to match your improvement, it lets you measure your percentage for each kind of shot without any bookkeeping, and it allows you to easily compare your performance on a particular table or day with previous practice sessions. It’s adaptable to many kinds of aiming and position drills.

Let’s start with a draw drill. In figure 1, the object ball is always near the long rail just out of the pocket jaws. Start with the cue ball in position 1, one diamond from the corner. The goal is to draw the cue ball back at least to 1. Each time you get enough draw, move the cue ball a diamond further back. For example, if you make the shot from 1, the next shot is from 2 and you have to draw the cue ball back at least to 2. If you do 2, try 3 next.

When you miss either the shot or the draw, the cue ball goes a diamond closer to the object ball. If you miss at 3, your next shot is from 2. Continue adjusting the distance after each shot until you’ve pocketed all 15 balls. Note your final position.

Let’s grade the result. If you ended at 1 or 2, you get a B for “beginner”. A few minutes of instruction from the local pool professor should be beneficial. If you ended between 3 and 5, you get an A for “average.” That’s enough draw for most draw situations. If you ended between 6 and the end rail, chalk up an E for “enough” for nearly all draw shots.

Because you make each shot a diamond easier or harder if you miss or make the shot, the final position is close to your 50% success point. Shorter distances are better than even money for you, while at longer distances the odds are against you. If you want to know your 50-50 point more accurately, redo the drill starting from your last position but change the distance only 1/4 diamond each time. The smaller changes result in a smaller error in the measurement.

A somewhat easier progressive drill using the same position is a stop shot. The goal is to pocket the object ball and leave the cue ball within a diamond of the pocket. Ideally the cue ball won’t move at all after it hits the object ball.

If you need a harder drill, draw the cue back to within a hand span of its starting position. You lose for too much or too little draw or wandering away from the rail. Put your thumb tip on the nose of the rail where the cue started. Your little finger must reach to the cue ball for the shot to be good. Very tough to get to 6.

A pure aiming drill is shown in figure 2. The object ball starts on the spot, and the cue ball is a diamond from the rail. Above average players will be able to turn the corner at position 5. The usual way to practice spot shots is to play from the same position over and over with the dangers of boredom and grooving the aim to a single specific shot. The shots under progressive practice continuously change and force you to aim anew each time.

The 50-50 point gives a good mix of challenge and reward which results in rapid improvement, but the system can be modified to find other percentages. To find the point at which you make 2/3 and miss 1/3 of the time, simply make the position two notches easier when you miss and one notch tougher when you make (where a “notch” might be a quarter diamond). When you’ve settled in on the 67% distance, you’ll make two for each one you miss and have no net motion.

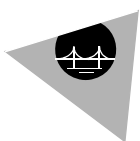

Progressive Practice

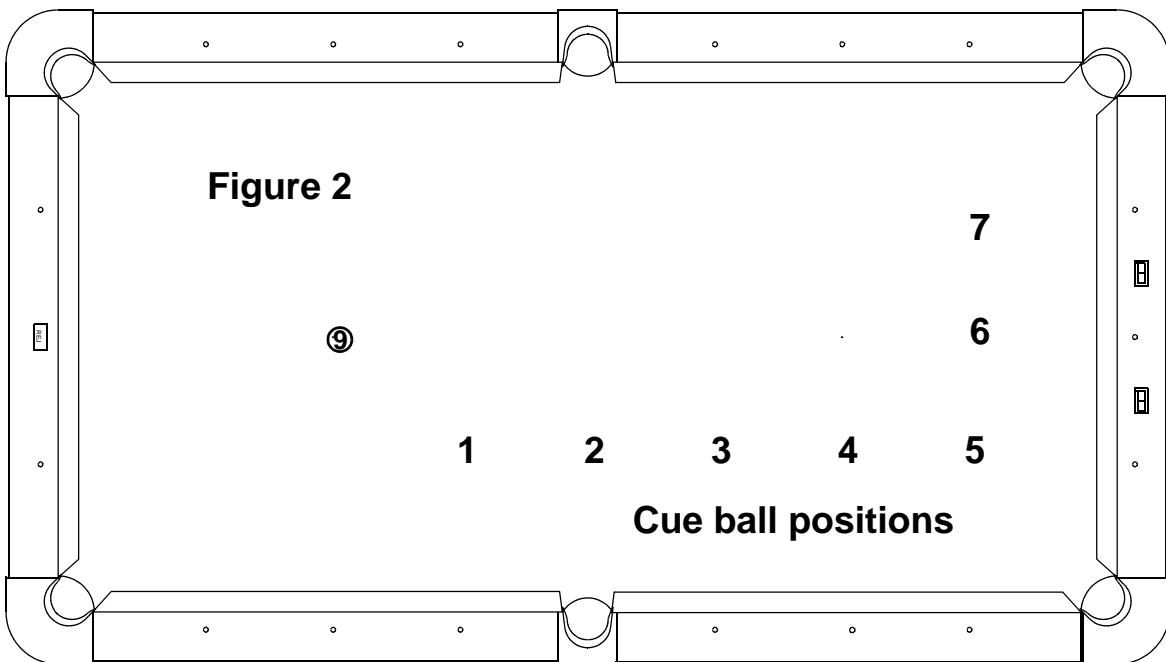
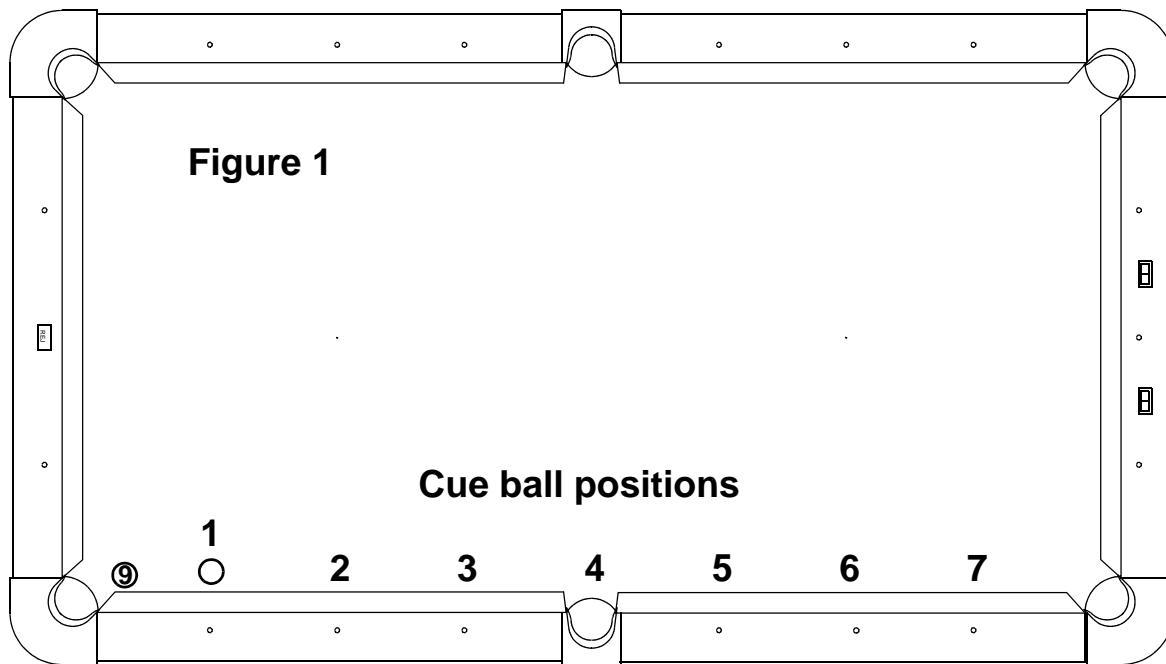

While you're at it, don't forget your other side! The draw drill will be extra tough on the side of the table where it requires either a bridge or shooting wrong-handed. Either way, you can find out how much accuracy you lose on your weak side. For the spot shot, there should be very little difference in the two sides. If there is consistently a large difference, there is likely a fundamental flaw in your aiming or stroke and it's time to get back to basics.

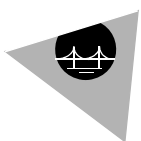

Progressive Practice

1A

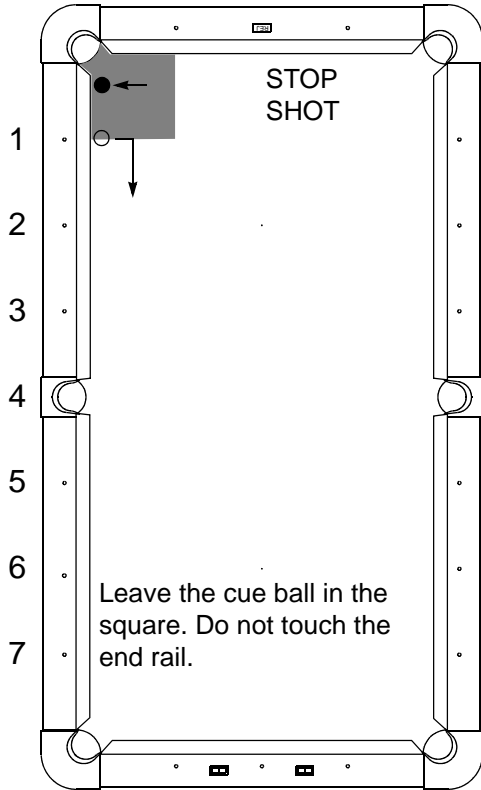

1B

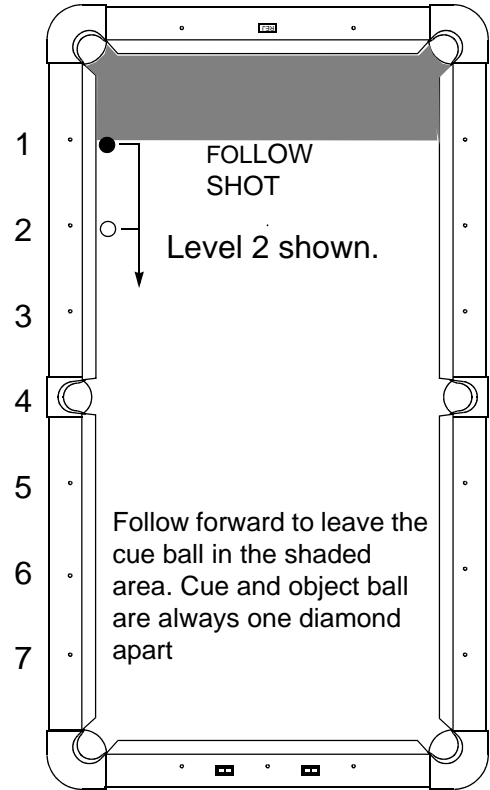

1C

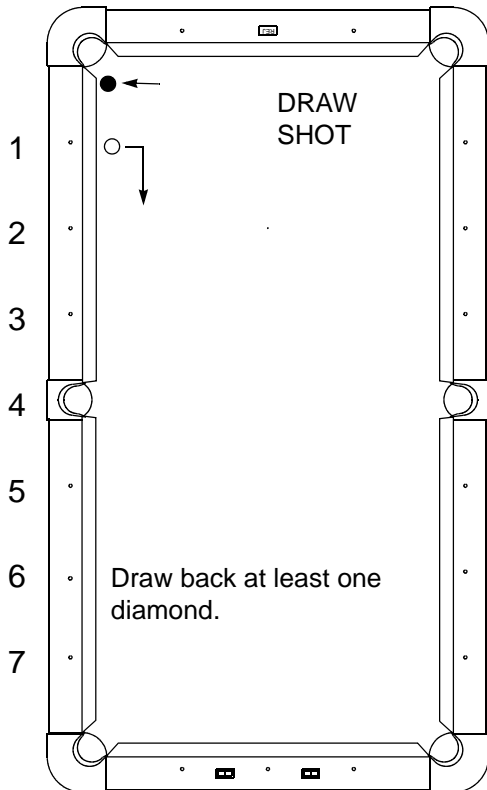

1D

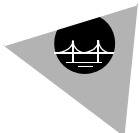
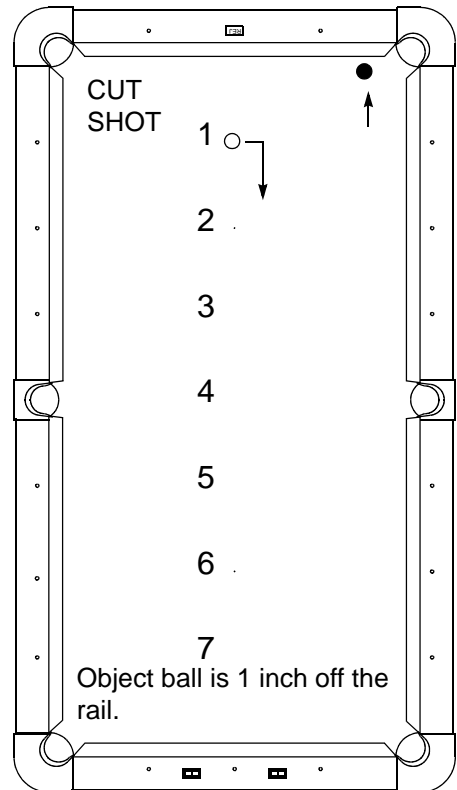

Progressive Practice

2A

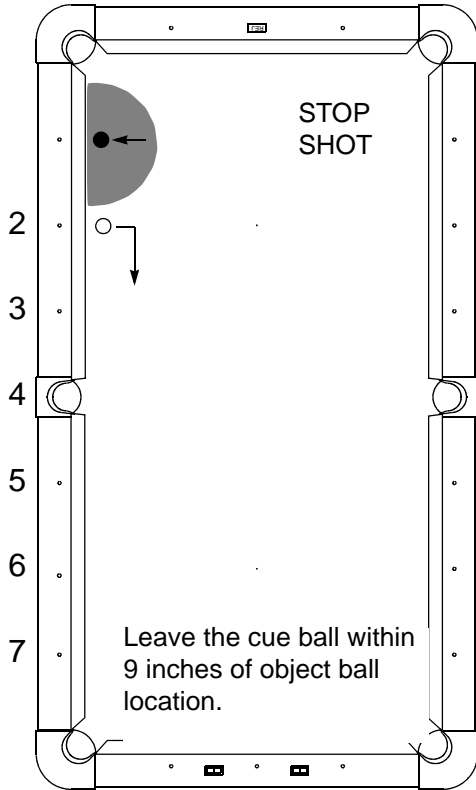

2B

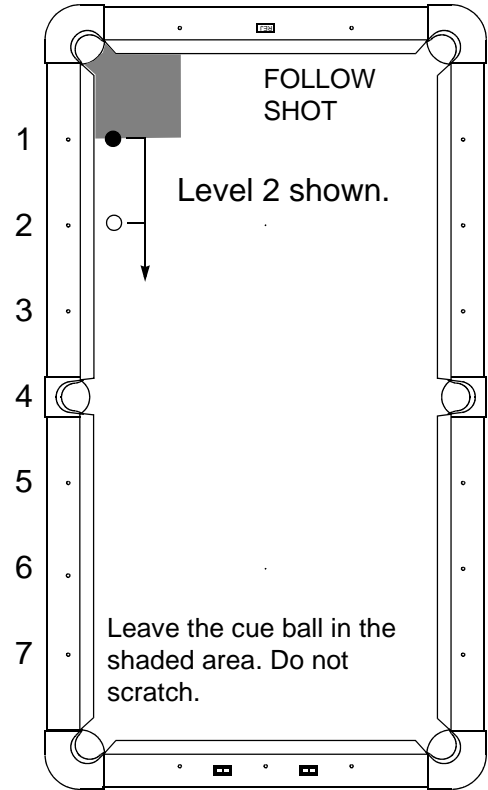

2C

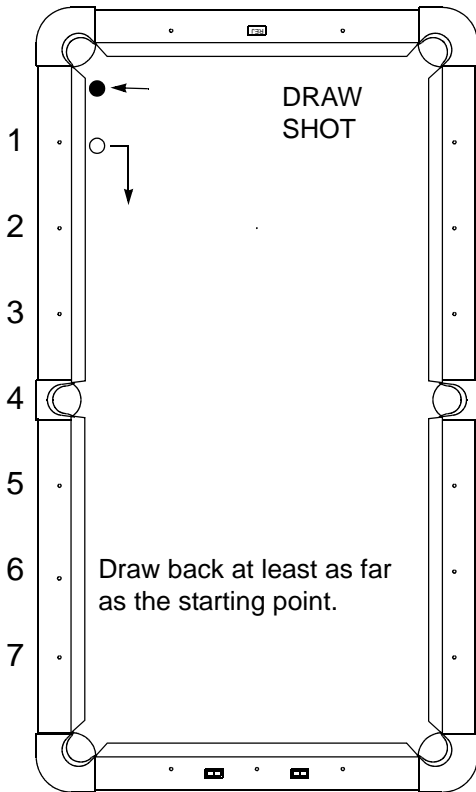

2D

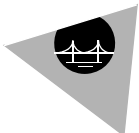
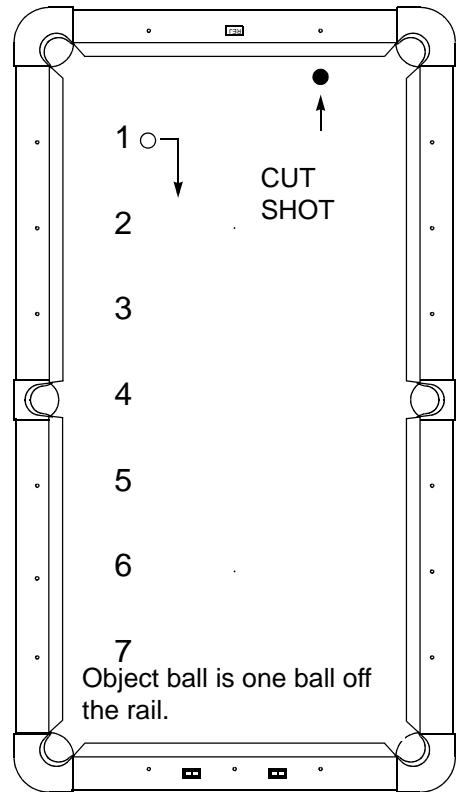

Progressive Practice

3A

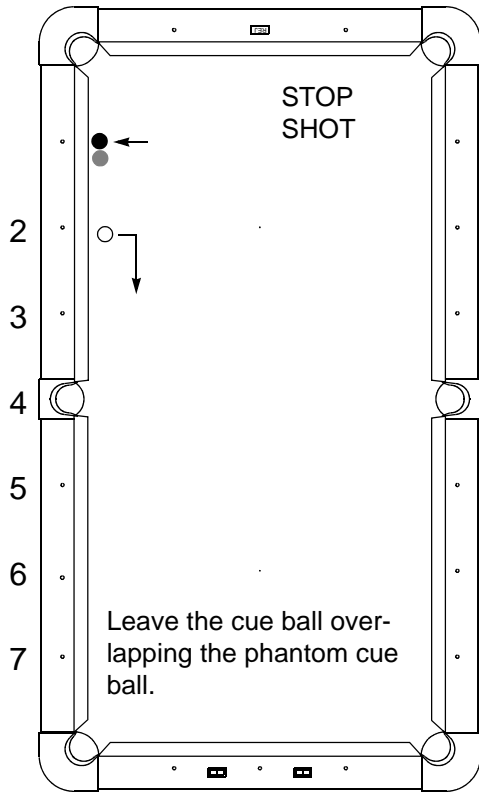

3B

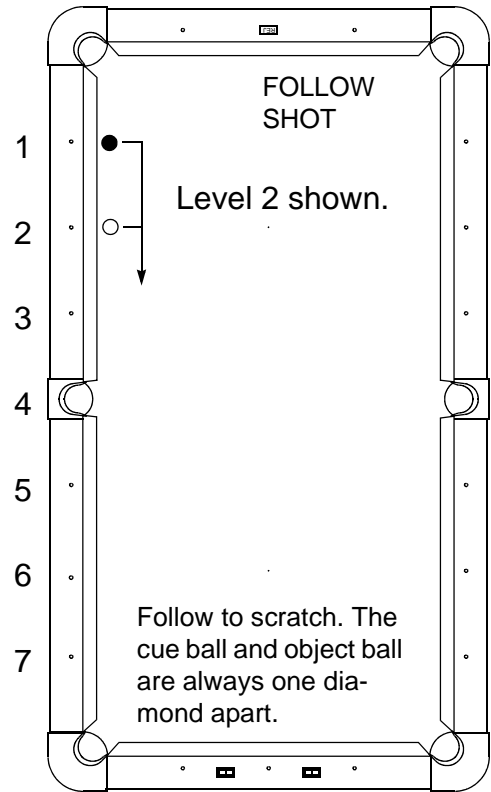

3C

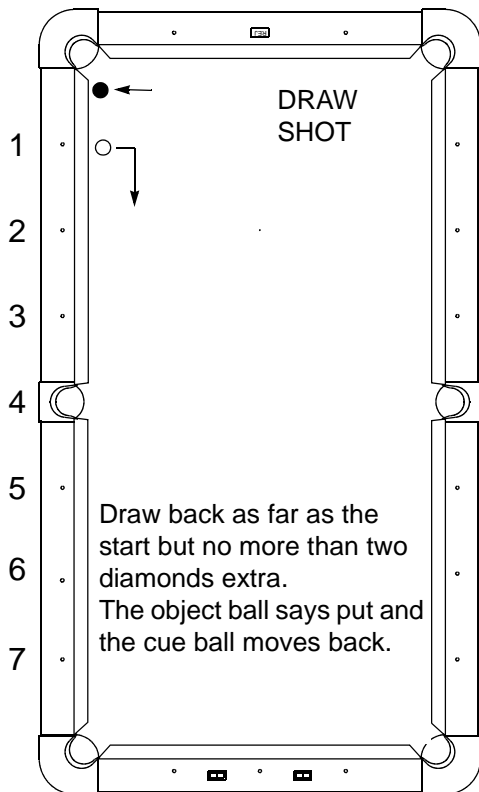

3D

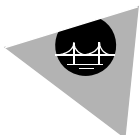
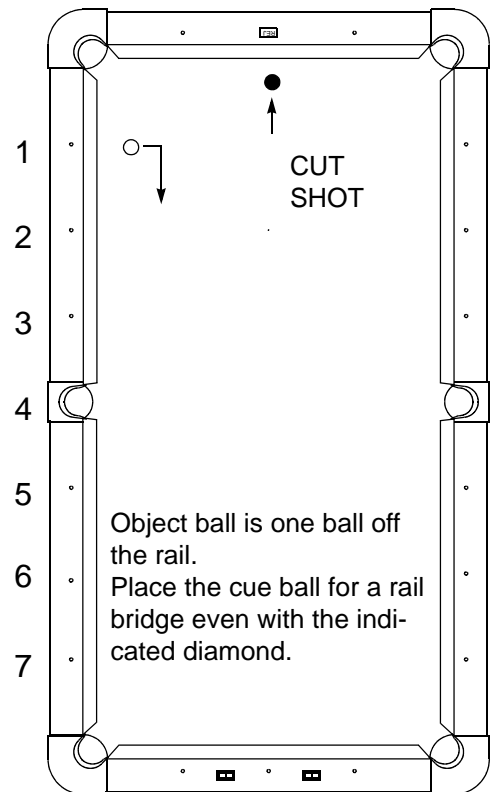

Progressive Practice

4A

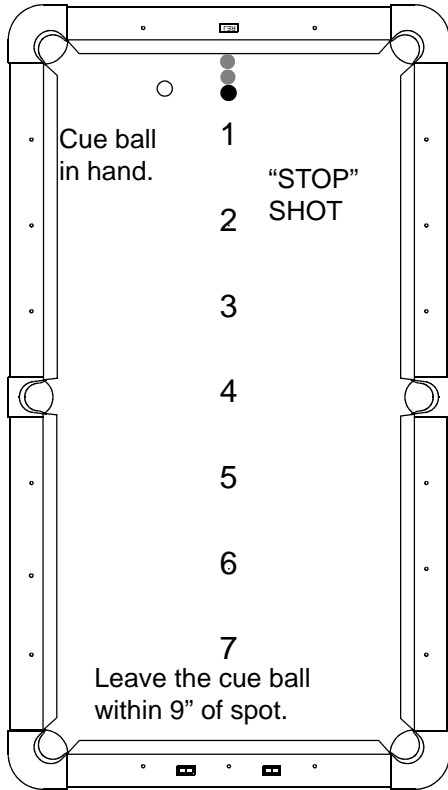

4B

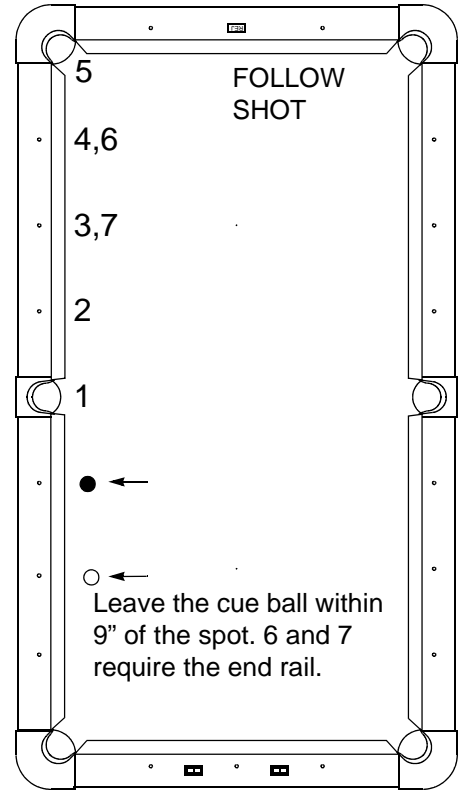

4C

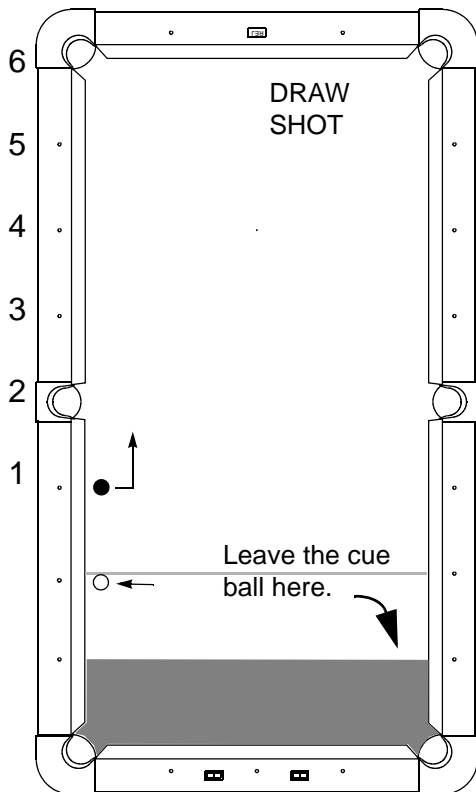

4D

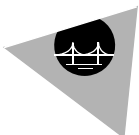
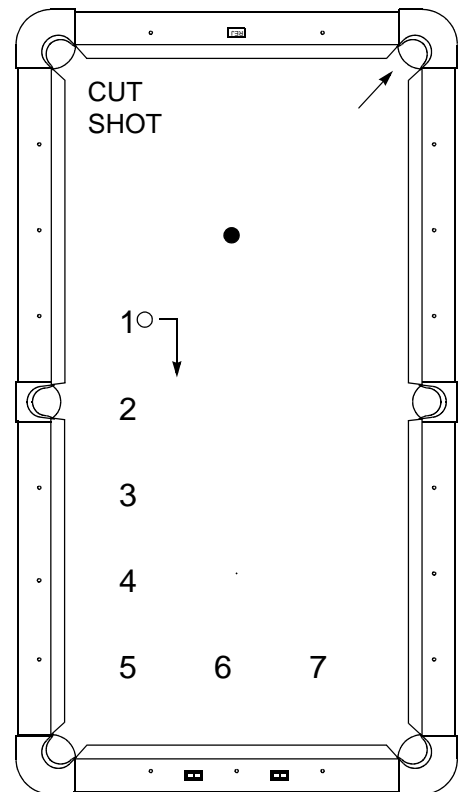

Progressive Practice

5A

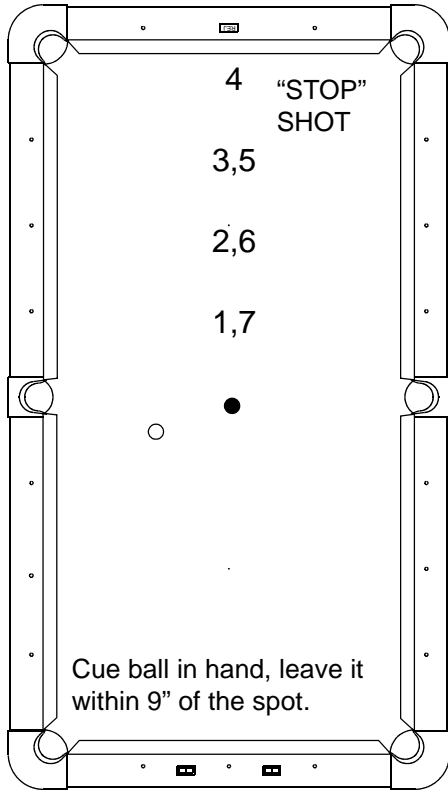

5B

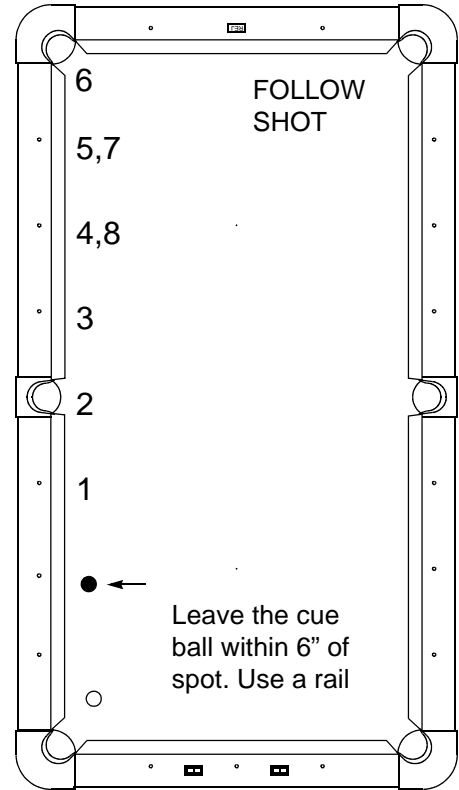

5C

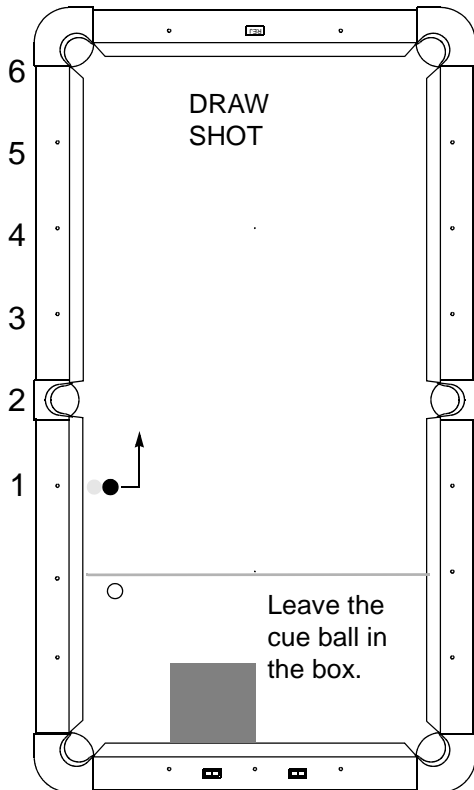

5D

